



TRUE FOOD SERVICE EQUIPMENT, INC.

2001 East Terra Lane • P.O. Box 970 • O'Fallon, Missouri 63366
(636)240-2400 • Fax (636)272-2408 • (800)325-6152 • Intl Fax# (001)636-272-7546
Parts Dept. (800)424-TRUE • Parts Dept. Fax# (636)272-9471 • www.truemfg.com

Project Name: _____

Location: _____

Item #: _____ Qty: _____

Model #: _____

A/A #

SIS #

Model:
TS-28-PT

Deep TS Series: Pass-Thru 300 Series Stainless Steel Solid Door Refrigerator



TS-28-PT

- ▶ True's TS series is the choice for the exclusive 300 series stainless steel commercial application.
 - ▶ Pass-thru design allows for convenient rear loading and front access for serving.
 - ▶ Designed using the highest quality materials and components to provide the user with colder product temperatures, lower utility costs, exceptional food safety and the best value in today's food service marketplace.
 - ▶ Oversized, factory balanced, refrigeration system holds 33°F to 38°F (.5°C to 3.3°C) for the best in food preservation.
 - ▶ 300 series stainless steel interior and exterior. The very finest stainless with higher tensile strength for fewer dents and scratches.
 - ▶ Adjustable, heavy duty chrome shelves.
 - ▶ Positive seal self-closing door(s). Lifetime guaranteed door hinges and torsion type closure system.
- Bottom mounted units feature:**
- ▶ "No stoop" lower shelf.
 - ▶ Storage on top of cabinet.
 - ▶ Compressor performs in coolest, most grease free area of kitchen.
 - ▶ Easily accessible condenser coil for cleaning.

ROUGH-IN DATA

Specifications subject to change without notice.

Chart dimensions rounded up to the nearest 1/8" (millimeters rounded up to next whole number).

Model	Doors	Capacity (Cu. Ft.) (liters)	Shelves	Cabinet Dimensions (inches) (mm)			HP	Voltage	Amps	NEMA Config.	Cord Length (total ft.) (total m)	Crated Weight (lbs.) (kg)
				L	D	H*						
TS-28-PT	2	28 793	3	29 737	35 1/8 893	78 3/8 1991	1/2	115/60/1	9.6	5-15P	9 2.74	390 177

* Height does not include 5" (127 mm) for castors or 6" (153 mm) for optional legs.



APPROVALS:

AVAILABLE AT:

Model:
TS-28-PT

Deep TS Series:
Pass-Thru 300 Series Stainless Steel Solid Door Refrigerator



STANDARD FEATURES

DESIGN

- True's solid door reach-in's are designed with enduring quality that protects your long term investment.
- True's commitment to using the highest quality materials and oversized refrigeration systems provides the user with colder product temperatures, lower utility costs, exceptional food safety and the best value in today's food service marketplace.

REFRIGERATION SYSTEM

- Factory engineered, self-contained, capillary tube system using environmentally friendly (CFC free) 134A refrigerant.
- Extra large evaporator coil balanced with higher horsepower compressor and large condenser; maintains 33°F to 38°F (.5°C to 3.3°C) for the best in food preservation.
- Sealed, cast iron, self-lubricating evaporator fan motor(s) and larger fan blades give True reach-in's a more efficient, low velocity, high volume airflow design. This unique design ensures faster temperature recovery and shorter run times in the busiest of food service environments.
- Bottom mounted condensing unit positioned for easy maintenance. Compressor runs in coolest and most grease free area of the kitchen. Allows for storage area on top of unit.

CABINET CONSTRUCTION

- Exterior - 300 series stainless steel doors, front, back and sides.
- Interior - 300 series stainless steel liner and floor.
- Insulation - entire cabinet structure and solid doors are foamed-in-place using high density, CFC free, polyurethane insulation.
- Welded, heavy duty galvanized frame rail dipped in rust inhibiting enamel paint for corrosion protection inside and out.

- Frame rail fitted with 4" (102 mm) diameter stem castors - locks provided on front set.

DOORS

- 300 series stainless steel exterior and liner. Doors extend full width of cabinet shell. Door locks standard.
- Positive seal self-closing doors. Lifetime guaranteed door hinges and torsion type closure system.
- Lifetime guaranteed recessed door handles. Each door fitted with 12" (305 mm) long recessed handle that is foamed-in-place with a sheet metal interlock to ensure permanent attachment.
- Magnetic door gaskets of one piece construction, removable without tools for ease of cleaning.

SHELVING

- Three (3) adjustable, heavy duty chrome shelves 25" L x 26⁹/₁₆" D (635 mm x 674 mm). Four (4) plastic support knobs included per shelf. Shelving ships separately (field installed).
- Four (4) different interior kits available (see Kit Options). Pilasters and tray slides are shipped separately (requires field installation).

LIGHTING

- Incandescent interior lighting - safety shielded. Lights activated by rocker switch mounted above top doors.

MODEL FEATURES

- Evaporator is epoxy coated to eliminate the potential of corrosion.
- Exterior mounted solar, digital temperature display.
- NSF-7 compliant for open food product.

ELECTRICAL

- Unit completely pre-wired at factory and ready for final connection to a 115/60/1 phase - 15 amp dedicated outlet. Cord and plug set included.



115/60/1
NEMA-5-15R

OPTIONAL FEATURES/ACCESSORIES

Upcharge and lead time may apply.

- 6" (153 mm) standard legs.
- 6" (153 mm) seismic/flanged legs.
- Additional shelves.
- Remote cabinets (condensing unit supplied by others; system comes standard with 404A expansion valve and requires R404A refrigerant), consult factory technical service department for BTU information.
- Kit #1: Nine (9) sets of #1 type tray slides and pilasters (field installed)(shipped separately), bottom support of one (1) 18" L x 26" D (458 mm x 661 mm) pan or two (2) 14" L x 18" D (356 mm x 458 mm) pans.
- Kit #2: One (1) set half-section #2 steel rod tray slides and pilasters (field installed)(shipped separately), rim support of one (1) 18" L x 26" D (458 mm x 661 mm) pan.
- Kit #3: Six (6) sets of universal type tray slides and pilasters (field installed)(shipped separately), bottom support of one (1) 18" L x 26" D (458 mm x 661 mm) pan, two (2) 12" L x 20" D (305 mm x 508 mm) pans or two (2) 14" L x 18" D (356 mm x 458 mm) pans.
- Kit #4: Three (3) PVC coated shelves 25" L x 27³/₄" D (635 mm x 705 mm). Four (4) shelf supports included per shelf (field installed). Shelves adjustable on 6" (153 mm) increments.
- Additional kit option components available individually.

PLAN VIEW

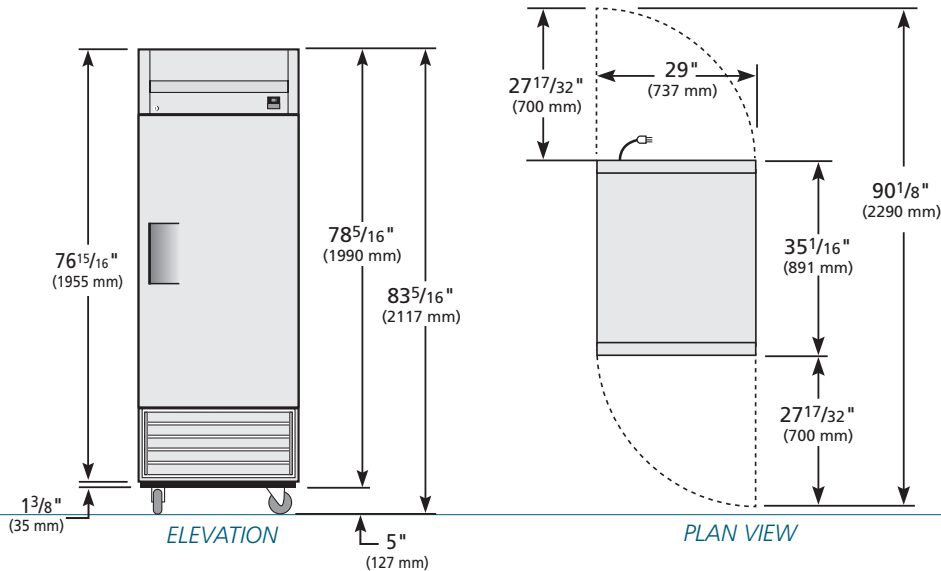

WARRANTY
 One year warranty on all parts & labor and an additional 4 year warranty on compressor. (U.S.A. only)

METRIC DIMENSIONS ROUNDED UP TO THE NEAREST WHOLE MILLIMETER
 SPECIFICATIONS SUBJECT TO CHANGE WITHOUT NOTICE



Model	Elevation	Right	Plan	3D
TS-28-PT	TFQH11E	TFQH14S	TFQH14P	TFQH143

TRUE FOOD SERVICE EQUIPMENT