



TRUE FOOD SERVICE EQUIPMENT, INC.

2001 East Terra Lane • P.O. Box 970 • O'Fallon, Missouri 63366
 (636)240-2400 • Fax (636)272-2408 • (800)325-6152 • Intl Fax# (001)636-272-7546
 Parts Dept. (800)424-TRUE • Parts Dept. Fax# (636)272-9471 • www.truemfg.com

Project Name: _____

Location: _____

Item #: _____ Qty: _____

Model #: _____

AIA #

SIS #

Model:
TR1DT-2HS

TR Series:

Reach-In Solid Half Door Dual Temperature Refrigerator/Freezer



TR1DT-2HS

- ▶ Designed using the highest quality materials and components to provide the user with colder product temperatures, lower utility costs and exceptional food safety.
- ▶ Oversized, factory balanced, refrigeration systems. Top section refrigerator holds 33°F to 38°F (.5°C to 3.3°C). Bottom section freezer holds -10°F (-23.3°C).
- ▶ 300 series stainless steel exterior and interior. The very finest stainless with higher tensile strength for fewer dents and scratches.
- ▶ Equipped with one (1) interior kit option, factory installed. Four (4) different interior kits available.
- ▶ Positive seal self-closing doors with 120° stay open feature. Lifetime guaranteed door hinges.
- ▶ Lifetime guaranteed recessed door handles.
- ▶ Entire cabinet structure and solid doors are foamed-in-place using high density, CFC free, polyurethane insulation.

ROUGH-IN DATA

Specifications subject to change without notice.
 Chart dimensions rounded up to the nearest 1/8" (millimeters rounded up to next whole number).

Model	Doors	Capacity (Cu. Ft.) (liters)		Cabinet Dimensions (inches) (mm)			HP		Voltage	Amps	NEMA Config.	Cord Length (total ft.) (total m)	Crated Weight (lbs.) (kg)
		Ref.	Frz.	L	D†	H*	Ref.	Frz.					
TR1DT-2HS	2	13 369	13 369	29 737	34 ⁵ / ₈ 880	78 ¹ / ₄ 1988	1/5	1/3	115/60/1	13.2	5-20P	9 2.74	480 218

† Depth does not include 2³/₈" (60 mm) for rear freezer condensate enclosure.

* Height does not include 5" (127 mm) for castors or 6" (153 mm) for optional legs, and 1" (26 mm) for system mechanical components.



APPROVALS:

AVAILABLE AT:

Model:
TR1DT-2HS

TR Series:
Reach-In Solid Half Door Dual Temperature
Refrigerator/Freezer



STANDARD FEATURES

DESIGN

- True's solid door reach-in's are designed with enduring quality that protects your long term investment.
- Designed using the highest quality materials and components to provide the user with colder product temperatures, lower utility costs and exceptional food safety.

REFRIGERATION SYSTEM

- Two independent, self contained refrigeration systems; CFC free, environmentally friendly and factory balanced.
- R134A refrigerator refrigerant - R404A freezer refrigerant.
- Extra large evaporator coils balanced with higher horsepower compressors and large condensers maintains 33°F to 38°F (.5°C to 3.3°C) in the refrigerator section and -10°F (-23.3°C) in the freezer section.
- Sealed, cast iron, self-lubricating evaporator fan motor(s) and larger fan blades give True reach-in's a more efficient low velocity, high volume airflow design. This unique design ensures faster temperature recovery and shorter run times in the busiest of foodservice environments.
- Top mounted refrigeration system with evaporator positioned out of food zone to maximize interior capacity.
- Freezer automatic defrost system is time-initiated, time-terminated.
- Automatic evaporator fan motor delay during defrost cycle.

CABINET CONSTRUCTION

- Exterior - 300 series stainless steel doors, front, sides, back and bottom.
- Interior - 300 series stainless steel liner and floor.
- Insulation - entire cabinet structure and solid doors are foamed-in-place using high density, CFC free, polyurethane insulation.
- Welded, heavy duty galvanized frame rail dipped in rust inhibiting enamel paint for corrosion protection inside and out.

- Frame rail fitted with 4" (102 mm) diameter stem castors - locks provided on front set.

DOORS

- 300 series stainless steel exterior and liners. Doors open within cabinet dimension.
- Door locks standard.
- Lifetime guaranteed recessed door handles. Each door fitted with 12" (305 mm) long recessed handle that is foamed-in-place with a sheet metal interlock to ensure permanent attachment.
- Positive seal self-closing doors with 120° stay open feature. Lifetime guaranteed door hinges.
- Magnetic door gaskets of one piece construction, removable without tools for ease of cleaning.

SHELVING

- One (1) factory installed, interior kit option. Four (4) different interior kits available (see Kit Options). Pilasters and tray slides are factory installed at no charge.

LIGHTING

- Compartmentalized incandescent interior lighting (one per door), safety shielded.

MODEL FEATURES

- Two (2) exterior digital temperature displays. Available with either °F or °C.
- Evaporator is epoxy coated to eliminate the potential of corrosion.
- Backguard in freezer section improves airflow.
- Minimum wattage heater in cabinet frame and in freezer door.
- NSF-7 compliant for open food product.

ELECTRICAL

- Unit completely pre-wired at factory and ready for final connection to a 115/60/1 phase, 20 amp dedicated outlet. Cord and plug set included.



115/60/1
NEMA-5-20R

OPTIONAL FEATURES/ACCESSORIES

Upcharge and lead times may apply.

- 6" (153 mm) standard legs.
- 6" (153 mm) seismic/flanged legs.
- 6" (153 mm) stainless steel legs.
- Stainless steel rail skirt for use with legs (field installed).
- Metal door handles (factory installed).
- Novelty baskets.
- Electronic temperature control (factory installed).
- Curb mountable units.
- Remote cabinets (condensing unit supplied by others; system comes standard with 404A expansion valve and requires R404A refrigerant). Consult factory technical service department for BTU information.

KIT OPTIONS

- Kit #1: Nine (9) sets of #1 type tray slides and pilasters (factory installed), bottom support of one (1) 18"L x 26"D (458 mm x 661 mm) pan or two (2) 14"L x 18"D (356 mm x 458 mm) pans.
- Kit #2: One (1) set half-section #2 steel rod tray slides and pilasters (factory installed), rim support of one (1) 18"L x 26"D (458 mm x 661 mm) pan.
- Kit #3: Six (6) sets of universal type tray slides and pilasters (factory installed), bottom support of one (1) 18"L x 26"D (458 mm x 661 mm) pan, two (2) 14"L x 18"D (356 mm x 458 mm) pans or two (2) 12"L x 20"D (305 mm x 508 mm) pans.
- Kit #4: Three (3) chrome shelves 25"L x 27³/₄"D (635 mm x 705 mm). Four (4) shelf supports included per shelf (factory installed); adjustable on 6" (153 mm) increments. Optional wall mounted shelf support pilasters (factory installed) with four (4) shelf clips per shelf available; adjustable on 1/2" (13 mm) increments.
- Additional kit option components available individually.

PLAN VIEW

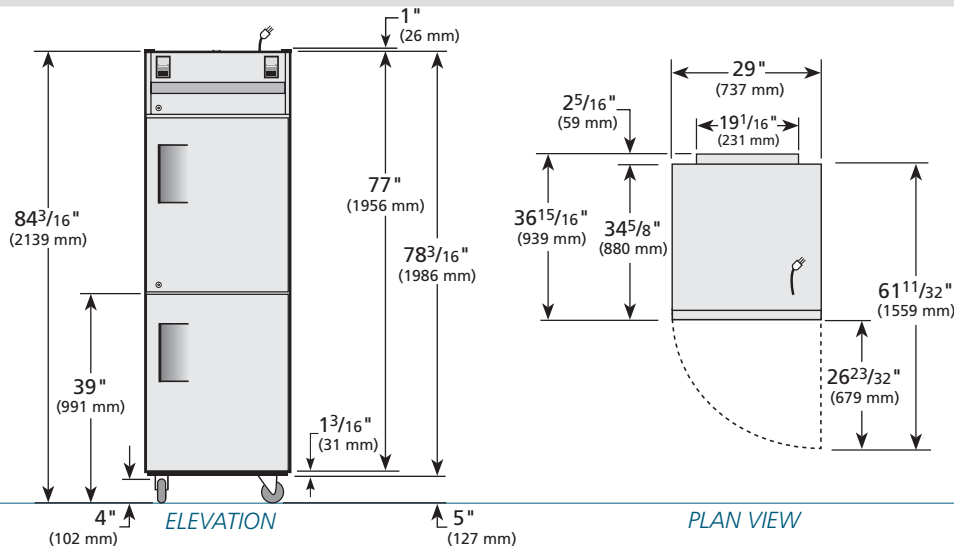

WARRANTY

One year warranty on all parts and labor and an additional 4 year warranty on compressor. (U.S.A. only)

METRIC DIMENSIONS ROUNDED UP TO THE NEAREST WHOLE MILLIMETER

SPECIFICATIONS SUBJECT TO CHANGE WITHOUT NOTICE



Model	Elevation	Right	Plan	3D
TR1DT-2HS	TFQH01E	TFQH01S	TFQH01P	TFQH013

TRUE FOOD SERVICE EQUIPMENT

2001 East Terra Lane • P.O. Box 970 • O'Fallon, Missouri 63366 • (636)240-2400 • Fax (636)272-2408 • (800)325-6152 • Intl. Fax# (001)636-272-7546 • www.truemfg.com