



GLOBE FOOD EQUIPMENT COMPANY

Vegetable Cutters

GFP700/GFP750

Project	Item #	Quantity



GFP700/ GFP750 Vegetable Cutters

Models

- GFP700 Vegetable Cutter
- GFP750 Chef's Choice Vegetable Cutter
Creates Brunoise (small diamond shape) and Gaufrette (waffle design) cuts

Processes up to 1,700 lbs. per hour
Ideal for up to 1,000 servings per meal



Standard Features

- 1 1/2 HP gear driven motor
- Plate speed of 280 RPMs
- Thermal overload protection
- Polished cast aluminum construction
- Interlocked hopper head and food pusher
- Ergonomic 45° food hopper incline
- Removable hopper head and food pusher (no tools required)
- Discs are rigid cast aluminum
- Stainless steel knives are hardened, ground, and hand polished
- 41 discs are available for the GFP700
- 45 discs are available for the GFP750
- No discs are included with unit, must be ordered separately

Optional Accessories

- Horizontal disc storage case
- 3 peg wall rack
- Adapter for continuous feed processing

Standard Warranty

- 2 years parts and labor

Approved By: _____

Date: _____



GLOBE FOOD EQUIPMENT COMPANY
www.globeslicers.com

2153 Dryden Rd
Dayton, OH 45439
Phone: 937-299-5493
Phone: 800-347-5423
Fax: 937-299-4147



Vegetable Cutters

GFP700/GFP750

Motor: 1 1/2 HP, 115/60/1, 10 amps
Automatic reset thermal overload protection.

On/Off Latch: The hopper latch serves as the on/off switch and interlock for the hopper head. The unit will not operate with the hopper head open or unlatched.

Gear Drive: Sealed planetary gear transmission with permanent grease lubrication. Output 280 RPMs.

Design: Ergonomic 45° incline for convenient feeding, cutting, and ejection of food. Separate food hopper permits continuous cutting of long products. The foodpusher enables even pressure to be applied when cutting food. The hopper head, foodpusher and cutting discs are easily removable, without the use of tools, for quick cleaning.

Interlocks: The vegetable cutter will operate only if the hopper head is closed and latched. In addition, the vegetable cutter will operate only when the foodpusher is covering the food hopper opening.

Construction: The housing, removable hinged hopper head, food hoppers, removable food pusher and ejector plate are made of polished cast aluminum.

Cutting Discs: There are 41 (model GFP700) and 45 (model GFP750) cutting discs available. The discs are rigid cast aluminum. The knives are hardened, ground, and hand polished to a razor sharp edge for precision cutting and long life.

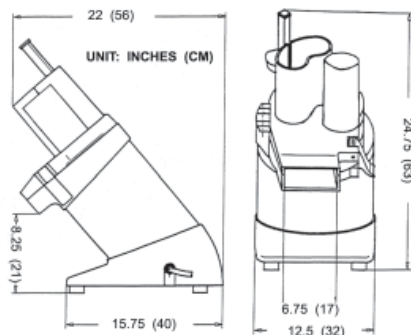

Specifications

Dimensions:
Foot Print = 12.5" x 15.75" (32cm x 40cm)
Overall Length = 22" (56cm)
Overall Width = 12.5" (32cm)
Overall Height = 24.75" (63cm)
Kidney Shaped Hopper = 3.25" x 7" (8.2cm x 17.8cm)
Continuous Feed Hopper =
GFP700 - 2.31" (5.9cm) diameter
GFP750 - 2.25" x 3" (5.7cm x 7.6cm)
Freight Class: 77.5
Net Weight: 78 lbs. (35 kgs.)
Shipping Weight:
GFP700 - 105 lbs. (47.5 kgs.)
GFP750 - 112 lbs. (50.7 kgs.)
Shipping Dimensions: 35"W x 19"D x 27"H (89cm x 48cm x 68cm)

Cord and Plug: Attached 6-foot flexible 3-wire cord and plug fits a grounded receptacle.

Optional Accessories:
SCH-7/4 Horizontal Disc Storage Case (holds four discs, welded stainless steel construction)

WR-3 3 Peg Wall Rack (holds three discs - not for cubing/dicing discs)

ADAPTER-7 Adapter converts kidney shaped hopper for continuous feed processing.

Cutting Discs Available:

Slicing	inches	mm
F1-7	1/32	1
F2-7	5/64	2
G3-7	1/8	3
G4-7	5/32	4
G6-7	15/64	6
G8-7	5/16	8
G10-7	3/8	10
G12-7	15/32	12
G16-7	5/8	16
SU5-7*	3/16	5
SU8-7*	5/16	8
*(SU discs are wavy slices)		
TO-7	3/16	5

Julienne	inches	mm
S1.5-7	1/16	1.5
S2-7	5/64	2
PA3-7	1/8	3
PA4-7	5/32	4
BT7-7	9/32	7

Shredding	inches	mm
11-7*	5/64	2
9-7*	3/32	2.5
K2.5-7	3/32	2.5
7-7*	1/8	3
4-7*	5/32	4
3-7*	3/16	5
1-7*	9/32	7
R-7*	23/64	9
00-7*	7/16	11

Grating	
14-7*	Fine cut
14FD-7	Fine Cut
K4-7*	Coarse cut
K4FD-7	Coarse cut
KP14-7	Potato grating disc

***A PH-9 Plate Holder is required to use these shredding and grating plates. The plates are interchangeable.**

French Fry	inches	mm
BT8-7	5/16	8
BT10-7	3/8	10

Cubing	inches	mm
W8-7	5/16	8
W10-7	3/8	10
W14-7	9/16	14

Cubing (Full Grid)	inches	mm
W8F-7	5/16	8
W10F-7	3/8	10
W14F-7	9/16	14

Dicing	inches	mm
W6-7	1/4 x 1/4 x 5/16	6 x 6 x 8
W28-7	1 1/8 x 1 1/8 x 9/16	28 x 28 x 14

For GFP750 Only

Brunoise	inches	mm
BR-7	1/8	3
BR4-7	5/32	4

Gaufrette	inches	mm
PG4-7	5/32	4
PG8-7	5/16	8

Disc Value Package:
DISC3PK-7 (includes an F2-7, G4-7, 3-7, PH-9, and a WR3)



GLOBE FOOD EQUIPMENT COMPANY
www.globeslicers.com

2153 Dryden Rd
Dayton, OH 45439
Phone: 937-299-5493
Phone: 800-347-5423
Fax: 937-299-4147

Printed in U.S.A. 3-2007