

SERIES '90

REFRIGERATED BAKERY CASE

OPTIONAL ACCESSORIES:

- * Package Shelf
- * Glass Shelves
- * Reflective Rear Doors
- * Special Base Finish
- * Remote Refrigeration
- * Casters (Self-Contained Models Only)
- * Front Glass & Rear Door Locks
- * Light Below Package Shelf
- * Gold Tone Trim
- * Reflective Ends
- * Rear Wrapping Board
- * Cord & Plug (Self-Contained Models Only)
- * Legs

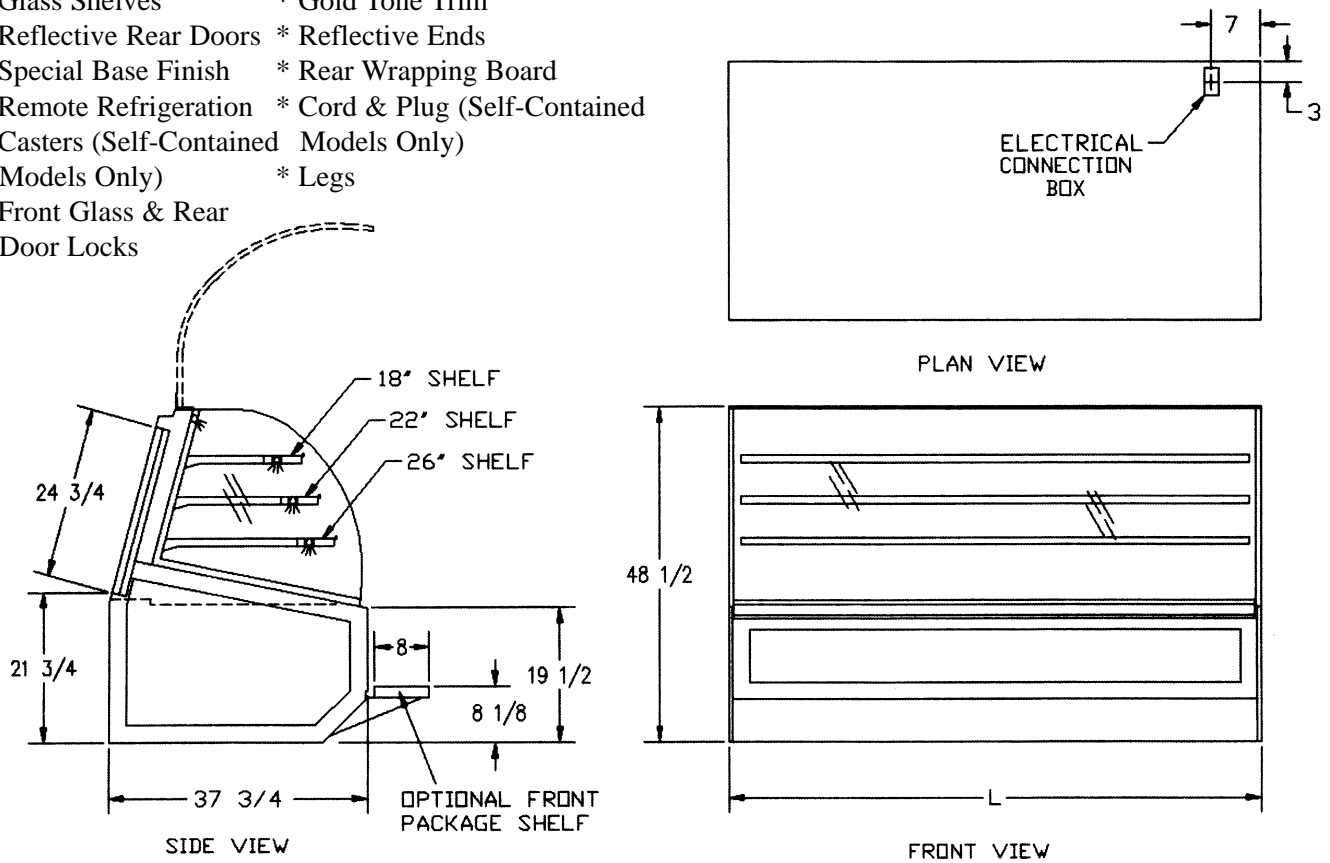

SPECIFICATIONS:

Model	Dimensions L W H	Shipping Weight (lbs)	Capacity (Bakery Pans)	Self-Contained 115/60/1	Remote 115/60/1
SNR-48SC	48 1/4" x 37 3/4" x 48 1/2"	750	4 (18" x 26") 8 (12" x 18") 2 (9" x 26")	1/2 HP - 12 AMPS	13.2 AMPS
SNR-59SC	59 1/4" x 37 3/4" x 48 1/2"	825	6 (18" x 26") 8 (12" x 18")	1/2 HP - 12 AMPS	13.2 AMPS
SNR-77SC	77 1/4" x 37 3/4" x 48 1/2"	1,050	8 (18" x 26") 12 (12" x 18")	3/4 HP - 16 AMPS	17.3 AMPS

- Cases are designed to operate in a maximum environment of 75° ambient and 55% relative humidity.
- Due to continuing engineering improvements, specifications are subject to change without notice.



Look to Federal for Innovative Merchandising



Federal Industries
A Standex Company
215 Federal Avenue
Belleville WI 53508
Call Toll Free: 1-800-356-4206
Telefax No. (608) 424-3234