

# HIGH VOLUME REFRIGERATED BAKERY CASE

## OPTIONAL ACCESSORIES:

- \* Special Base Finish
- \* Special Trim
- \* Glass Shelves
- \* Rear Wrapping Board
- \* Cord & Plug (Self-Contained Models Only)
- \* Remote Condensing Unit
- \* Reflective Ends
- \* White or Mirrored Interior Ends with Laminated Exterior
- \* Reflective Rear Doors
- \* Casters/Cord & Plug Included (Self-Contained Models Only)
- \* Legs
- \* Top Cutting Board, White
- \* Package Shelf
- \* Light Below Package Shelf
- \* Black, Gold, or Chrome Wire Shelves
- \* Front Glass and Rear Door Locks
- \* Joining Kit for Continuous Line-ups

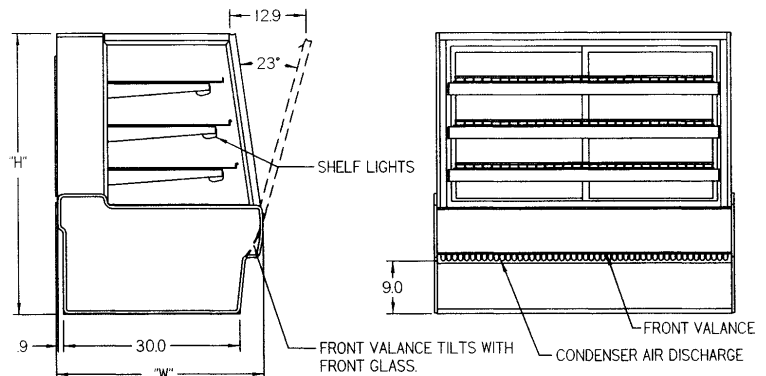
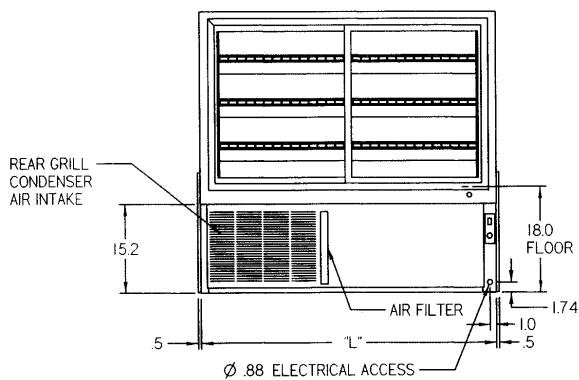
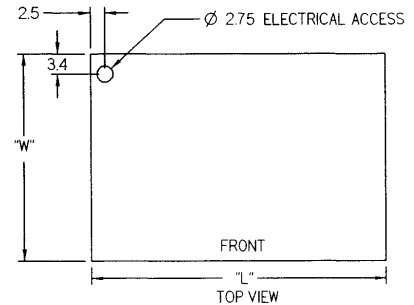

## SPECIFICATIONS:

Model	Dimensions			Bakery Pan Capacity	Self-Contained (120/60/1)	Remote (120/60/1)
	L	W	H			
SGR3148	31.13"	35.31"	48"	4 (18" x 26") & 4 (9" x 26")	1/3 HP - 8.0 AMPS	2.1 AMPS
SGR3642	36.13"	35.31"	42"	3 (18" x 26") & 3 (9" x 26")	1/3 HP - 9.0 AMPS	2.3 AMPS
SGR3648	36.13"	35.31"	48"	4 (18" x 26") & 4 (9" x 26")	1/3 HP - 9.0 AMPS	2.3 AMPS
SGR5042	50.13"	35.31"	42"	6 (18" x 26") & 3 (9" x 26")	1/2 HP - 10.5 AMPS	2.3 AMPS
SGR5048	50.13"	35.31"	48"	8 (18" x 26") & 4 (9" x 26")	1/2 HP - 10.5 AMPS	2.3 AMPS
SGR5942	59.13"	35.31"	42"	9 (18" x 26")	1/2 HP - 11.6 AMPS	2.5 AMPS
SGR5948	59.13"	35.31"	48"	12 (18" x 26")	1/2 HP - 11.6 AMPS	2.5 AMPS
SGR7742	77.13"	35.31"	42"	12 (18" x 26")	3/4 HP - 14.2 AMPS	3.3 AMPS
SGR7748	77.13"	35.31"	48"	16 (18" x 26")	3/4 HP - 14.2 AMPS	3.3 AMPS

- Refrigerated cases are designed to operate in a maximum environment of 75° ambient and 55% relative humidity.
- Due to continuing engineering improvements, specifications are subject to change without notice.



**Look to Federal for Innovative Merchandising**



**a Standex company**

**Federal Industries**  
**A Standex Company**  
**215 Federal Avenue**  
**Belleville WI 53508**  
**Call Toll Free: 1-800-356-4206**  
**Telefax No. (608) 424-3234**