

# CHOCOLATE & CONFECTIONERY CASE

## CLIMATE CONTROLLED / NON-REFRIGERATED

### OPTIONAL ACCESSORIES:

- \* Special Exterior Finishes
- \* Top Rear Wrapping Board
- \* Silver Trim
- \* Casters or Legs
- \* Cord and Plug

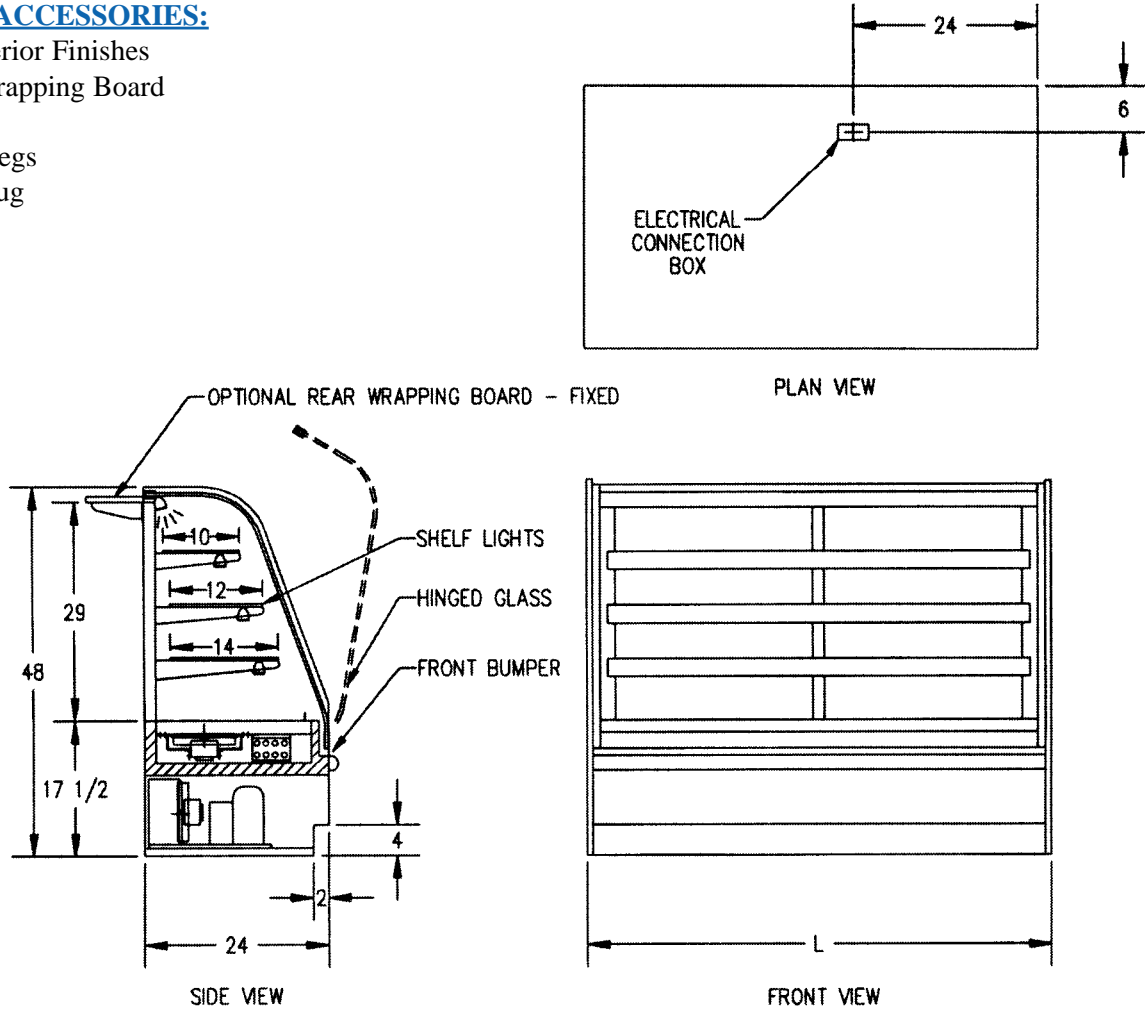

### SPECIFICATIONS:

Model		Dimensions L W H	Shipping Weight (lbs)		Max. Capacity Candy Trays	Power - 120/60/1	
Controlled	Non-Refrig.		Controlled	Non-Refrig.		Controlled	Non-Refrig.
FCCR-4	FCC-4	48" x 24" x 48"	635	585	16	9 AMP	2 AMP
FCCR-5	FCC-5	60 3/4" x 24" x 48"	690	640	28	9 AMP	2 AMP
FCCR-6	FCC-6	72" x 24" x 48"	745	695	32	10 AMP	2 AMP

- Standard Tray Sizes: 7 x 8 x 1 1/4; 7 x 10 x 1 1/4; 7 x 14 x 1 1/4
- Due to continuing engineering improvements, specifications are subject to change without notice.



**Look to Federal for Innovative Merchandising**



**a Standex company**

**Federal Industries**  
**A Standex Company**  
**215 Federal Avenue**  
**Belleville WI 53508**  
**Call Toll Free: 1-800-356-4206**  
**Telefax No. (608) 424-3234**