

CURVED GLASS REFRIGERATED DELI CASE

OPTIONAL ACCESSORIES:

- *Special Base Finish
- *Additional Mezzanine Shelf
- *Cord & Plug (Self-Contained Models Only)
- *Remote Refrigeration
- *Reflective Ends
- *White or Mirrored Interior Ends With Laminated Exterior
- *Reflective Rear Doors
- *Casters/Cord & Plug Included (Self-Contained Models Only)
- *Legs
- *Top Cutting Board, White
- *Package Shelf
- *Light Below Package Shelf
- *Front Glass and Rear Door Locks
- *Joining Kit for Continuous Line-ups
- *Scale Platform
- *Step Riser or Pan Holder

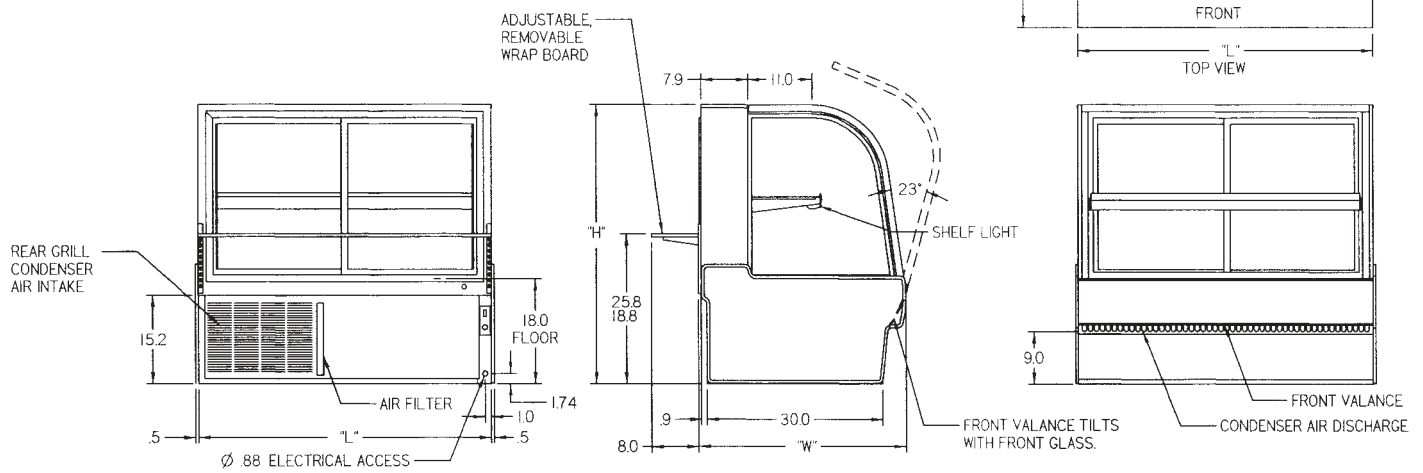

SPECIFICATIONS:

Model	Dimensions L W H	Shipping Weight (lbs)	Capacity (Step Risers)	Self-Contained 120/60/1	Remote 120/60/1
CGR5048CD	50.13" x 35.31" x 48"	620	3	1/2 HP - 10.5 AMPS	2.3 AMPS
CGR5948CD	59.13" x 35.31" x 48"	650	4	1/2 HP - 11.6 AMPS	2.5 AMPS
CGR7748CD	77.13" x 35.31" x 48"	870	6	3/4 HP - 14.2 AMPS	3.3 AMPS

- Refrigerated cases are designed to operate in a maximum environment of 75° ambient and 55% relative humidity.
- Due to continuing engineering improvements, specifications are subject to change without notice.



Look to Federal for Innovative Merchandising



a Standex company

Federal Industries
A Standex Company
215 Federal Avenue
Belleville WI 53508-0290
Phone: 800-356-4206
Fax: 608-424-3234
Email: geninfo@federalind.com
Web Site: www.federalind.com