



IG-409C



Standard features include baskets, basket dividers, thermometer and lock.



## IG-C SERIES

### Curved Lid Display Freezers

#### MODELS

- IG 209C
- IG 309C
- IG 409C
- IG 509C
- IG 609C

#### FEATURES

##### CONSTRUCTION

- Pre-painted steel exterior
- Stucco aluminum interior
- Heavy-duty 2<sup>1</sup>/<sub>2</sub>" casters
- Aluminum extrusion top frame
- Defrost water drain
- The unobtrusive frame around the heated glass lids ensures a highly visible display
- Curved top lids afford maximum product view
- Lids contain heated safety glass
- Low energy consumption

- 2<sup>3</sup>/<sub>8</sub>" insulation in sides and bottom

##### REFRIGERATION

- Refrigerant: R-134a
- Temperature range: 12° to -8°F (-11° to -22°C)
- R-factor (insulation efficiency rating): 17.24

##### WARRANTY

- Standard limited four year extended compressor and one year limited parts and labor

#### OPTIONS

- Additional baskets and dividers
- Lighted canopies
- Sneeze guards

#### STANDARD BASKET CONFIGURATIONS

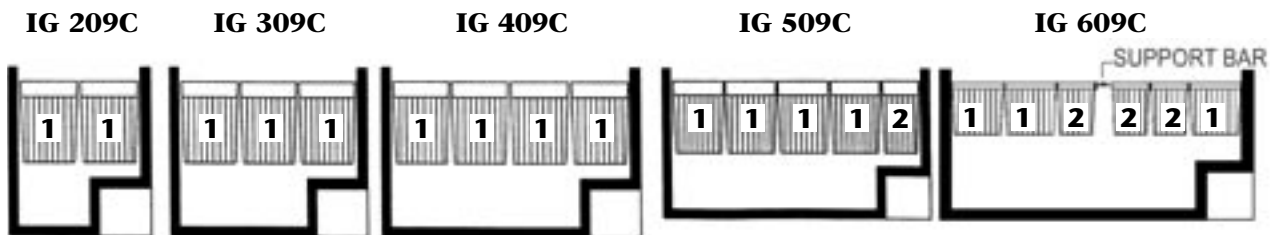

**1** = Basket with dimensions of 11<sup>1</sup>/<sub>4</sub>"W x 21<sup>3</sup>/<sub>4</sub>"D x 13<sup>1</sup>/<sub>8</sub>"H (includes one vertical divider and one horizontal divider)

**2** = Basket with dimensions of 8<sup>1</sup>/<sub>4</sub>"W x 21<sup>3</sup>/<sub>4</sub>"D x 13<sup>1</sup>/<sub>8</sub>"H (includes two horizontal dividers)



# COLDIN™ IG-C SERIES CURVED LID DISPLAY FREEZERS

## TECHNICAL SPECIFICATIONS

MODEL	DIMENSIONS (in.)			DIMENSIONS (mm)			VOLTS	AMPS	UNIT H.P.	INTERNAL VOLUME AT LOAD LINE CU. FT.	SHIP CU. FT.	SHIP WT. LB/KG
	L	D	H	L	D	H						
IG 209C	27 <sup>1</sup> / <sub>2</sub>	25 <sup>1</sup> / <sub>2</sub>	35	700	650	889	115	3.6	1/4	4.3	16.0	120/55
IG 309C	39 <sup>1</sup> / <sub>4</sub>	25 <sup>1</sup> / <sub>2</sub>	35	1000	650	889	115	3.6	1/4	7.1	22.0	145/66
IG 409C	51 <sup>1</sup> / <sub>4</sub>	25 <sup>1</sup> / <sub>2</sub>	35	1300	650	889	115	4.4	1/4	9.9	29.0	165/75
IG 509C	59	25 <sup>1</sup> / <sub>2</sub>	35	1500	650	889	115	5.0	1/2	11.8	33.0	185/84
IG 609C	67	25 <sup>1</sup> / <sub>2</sub>	35	1700	650	889	115	5.1	1/2	13.6	37.0	210/95

HIGH AMBIENT SPECIFICATIONS AVAILABLE ON REQUEST.

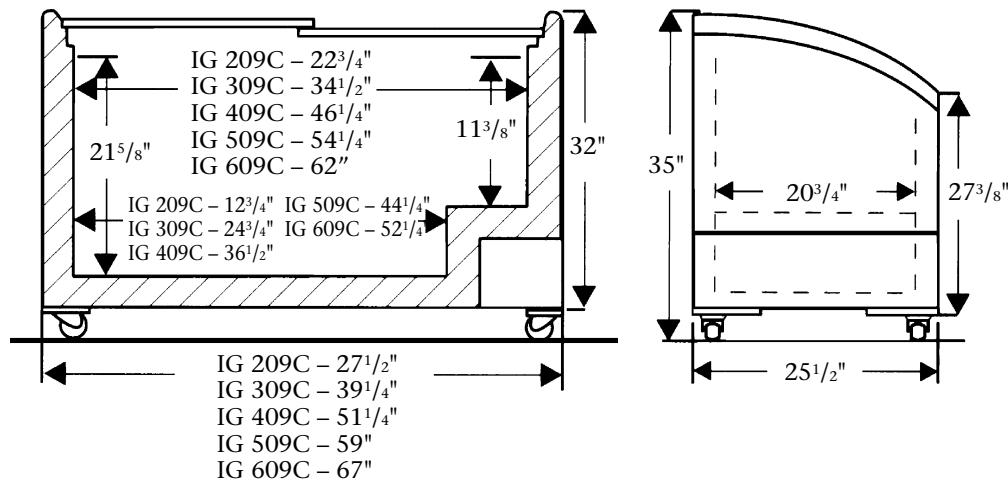

## LISTINGS



ANSI/NSF 7

## HOOKUP

Via plug in, 6<sup>1</sup>/<sub>2</sub> foot long, flexible 3 wire 18/3 cord with molded plug.



NEMA 5-15P

## BID SPECIFICATIONS

Item no. IG-\_\_\_\_\_C  
 Provide \_\_\_\_\_ ( ) Curved Lid Display Freezer(s) Master-Bilt model IG-\_\_\_\_\_C.

Freezer to be constructed of a pre-painted steel exterior with stucco aluminum interior. Sides and bottom of freezer will contain 2<sup>3</sup>/<sub>8</sub>" insulation. Freezer

to be furnished standard with baskets, basket dividers, thermometer and lock. Additionally, it will be provided with heavy-duty 2<sup>1</sup>/<sub>2</sub>" casters, an aluminum extrusion top frame and a defrost water drain. Lids will contain heated safety glass.

Refrigeration system will use R-134a refrigerant. The temperature range will be

12° to -8°F (-11° to -22°C).

Freezer to have standard limited four year extended compressor warranty and one year limited parts and labor. Freezer to be UL and C-UL listed as well as UL-EPH classified.

**NOTE:** Cabinet designed for optimum performance in air-conditioned area at 75°F ambient and 55% relative humidity. All specifications subject to change without notice.



908 Highway 15 North • New Albany, MS 38652  
 PHONE: 800-647-1284 or 662-534-9061 • FAX: 800-232-3966 or 662-534-6049 • www.master-bilt.com

