



# STAR-MAX® 15 lb. ELECTRIC FRYER Model 301HLD

Star-Max® 15 lb. Electric Fryer

### Features/Benefits:

- ★ Star's #1 selling 15 pound electric fryer offers excellent frying flexibility and fits almost any countertop requiring minimal space.
- ★ A 15 lb. lift-out nickel plated steel kettle for easy removal of grease or other cooking oils.
- ★ Immersion-type tubular heating elements provide even heat distribution and swing up design makes cleaning a snap.
- ★ Snap-action thermostat ranges from 200°F to 375°F and provides quick response to temperature change.
- ★ High-limit safety thermostat, on-off switch and indicator light provide safe and easy operation.
- ★ Two large nickel plated steel mesh side hanging baskets (5-5/32"W x 5-3/32"D x 10-11/16"L) provide continuous flow of product during peak periods
- ★ All stainless steel cabinet for maintenance free operation.
- ★ Heavy-duty 4" adjustable legs to match the height of other Star-Max® equipment in your line.

### Applications:

Star-Max® single pot electric fryer has a wide variety of frying capabilities and is perfect for today's diverse menu selections. No matter what the menu items; onion rings, fries, chicken or fish, Star-Max® electric fryer cooks food sealing in the flavor.

### Quality Construction:

Star's electric fryer features a control housing with indicator light, adjustable snap-action thermostat, hi-limit safety thermostat and immersion type elements are standard. Housing swings up to allow 15 lb. fat capacity kettle to be removed. Fryers operate on 208 or 240 volts with a 6' cord and plug.

### Warranty:

Star-Max® Electric Fryer is covered by Star's one year parts and labor warranty.



Model 301HLD





## STAR-MAX® 15 lb. ELECTRIC FRYER Model 301HLD

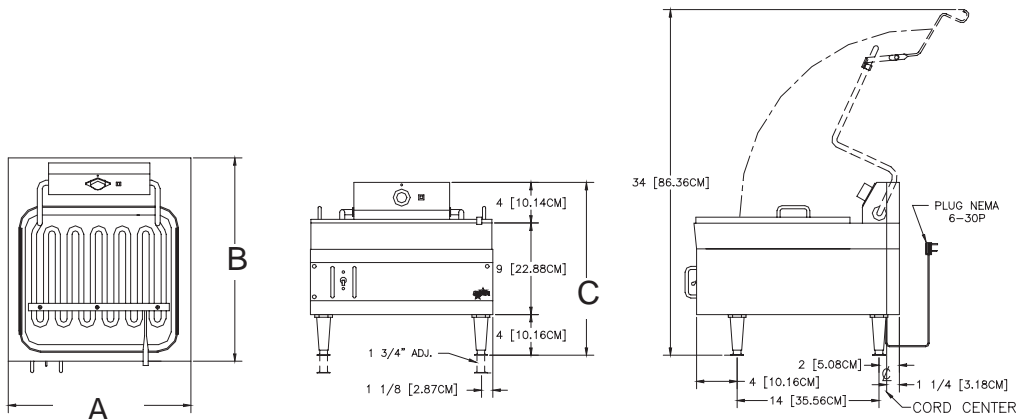

### Performance Data

Model No.	Pre-Heat to 350°F (177°C)	Fat Capacity	Pounds of French Fries Per Hour	Watts Per Hour To Maintain 350°F (177°C)
301HLD	5 Minutes	15 lbs. (6.8 kg)	28 lbs. (12.7 kg)	430

### Dimensions & Weight

Model No.	Overall Dimensions			Cooking Surface Height	Approximate Weight	
	(A) Width	(B) Depth	(C) Height		Installed	Shipping
	Inches (cm)	Inches (cm)	Inches (cm)	lbs. (kg)	lbs. (kg)	lbs. (kg)
301HLD	18 (45.7)	20 (50.8)	17 (43.2)	11 (27.9)	37 (16.8)	47 (21.3)

Model No.	Fat Container			Foam Compartment		
	Width	Depth	Height	Width	Depth	Height
Inches (cm)	Inches (cm)	Inches (cm)	Inches (cm)	Inches (cm)	Inches (cm)	Inches (cm)
301HLD	13 (33.0)	12 (30.4)	3-3/4 (9.5)	16 (40.6)	13 (33.0)	3-3/8 (8.6)

Legs adjustable 4" to 5-3/8" (10.2 cm to 13.7 cm)

### Electrical Data

Model No.	Rated Wattage		Nominal Amps		NEMA Plug
	208V	240V	208V	240V	
301HLD	4130	5500	19.9	22.9	6-30P

### Typical Specifications

Electric fryer has a stainless steel body with black polycarbonate trim on the front panel. A 200° - 375° (93°C - 190°C) adjustable thermostat and a hi-limit safety thermostat, and a separate on-off switch are standard. A one piece nickel plated, lift out 15 lb. (6.8 kg) capacity steel kettle and 4" nickel-plated die cast legs are standard. Unit has a tubular type, two position, swing-up element with a rated wattage of 5500 watts on 240 volts. Two side mounted nickel plated, perforated steel mesh baskets are provided as standard. A 6 ft. (182.9 cm) lead-in cord and plug with a NEMA 6-30P. Unit carries approval of Underwriters' Laboratories, National Sanitation Foundation and CSA. Printed in the U.S.A.